

Plaspanel® Installation Techniques

PART 1: EXPANSION & CONTRACTION

Issue: 4 October 2018

Technical Data Sheet

It is important when installing Plaspanel® (HDPE) that the material properties are considered such as expansion and contraction rates etc. particularly for external applications. These are guidelines to assist however due to variations in conditions you must ensure your installation is correct for your application.

Figure 1

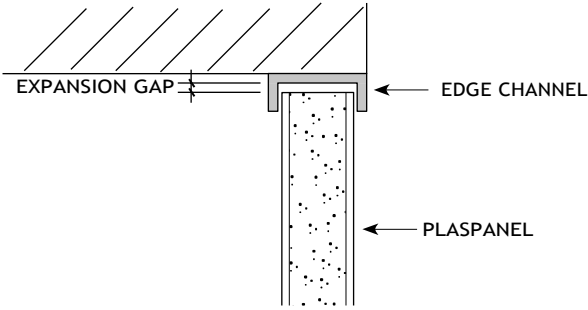

Figure 2

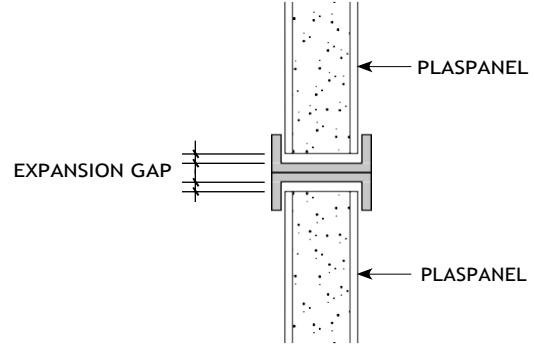

Figure 3

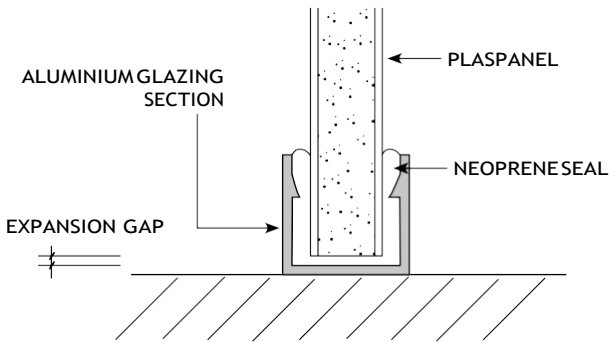

Figure 4

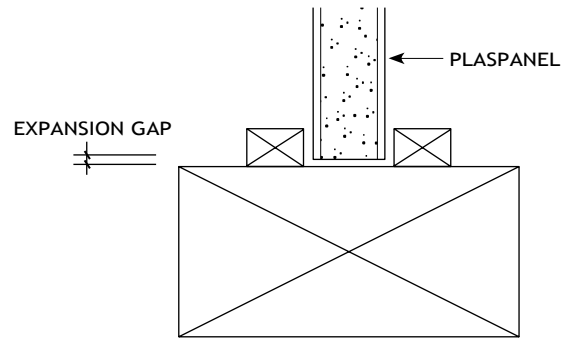

Figure 5

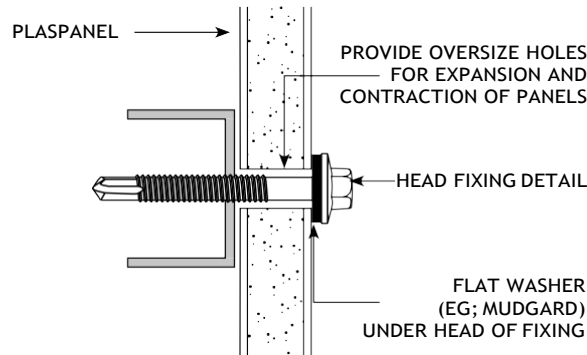
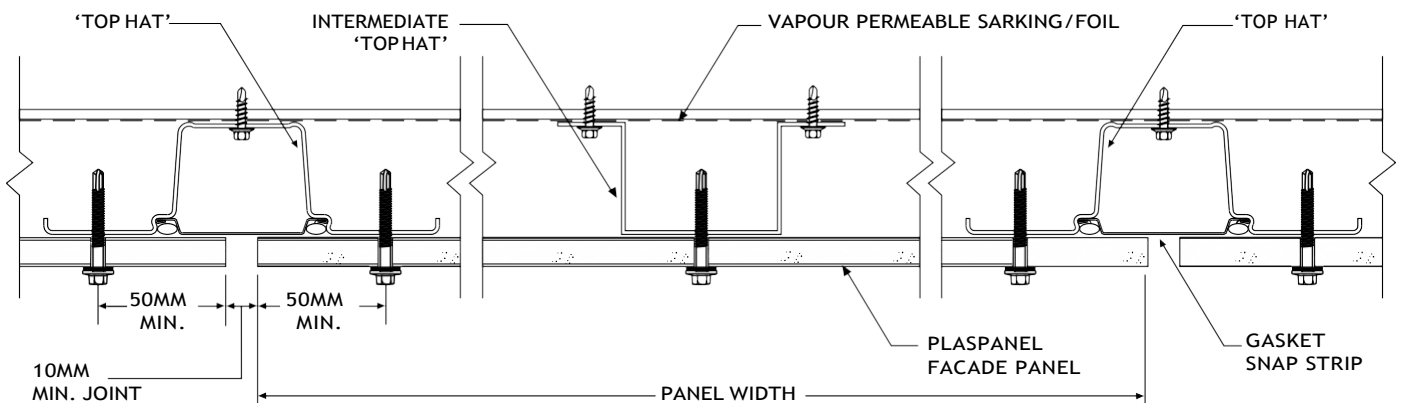

Figure 6

'Top Hat' & Panel Fixing Detail



NOTE: USE HEX. OR DOME HEAD SCREWS (WITH FLAT WASHER). DO NOT USE SELF EMBEDDING SCREWS. DO NOT FIX WITH FORCE. FIXING TO HOLD PANELS IN PLACE TO ALLOW FOR NATURAL EXPANSION & CONTRACTION.

Plaspanel® Installation Techniques

PART 2: EXPANSION & CONTRACTION

Issue: 4 October 2018

Expansion & Contraction Calculation

Figure 8

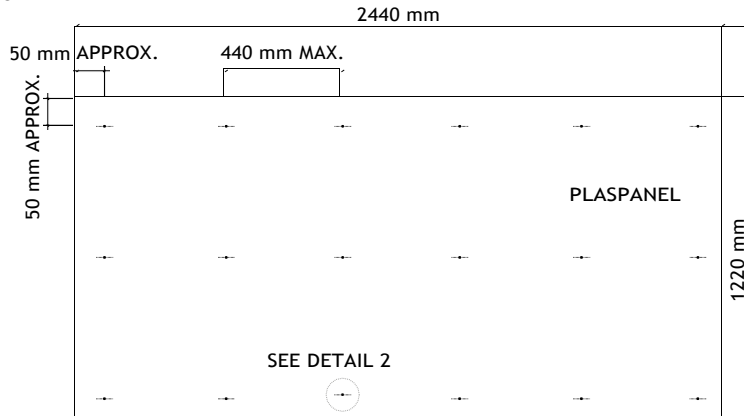

Detail 1

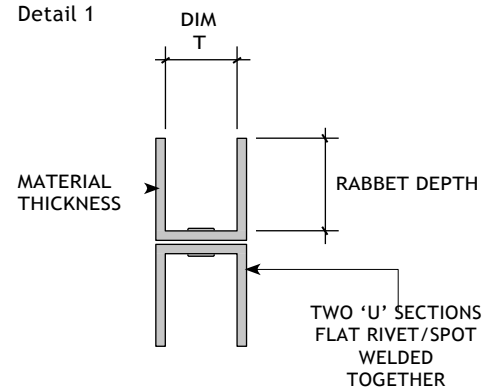

TO CALCULATE THE 'SHEET LENGTH' VARIATION DUE TO TEMPERATURE EXTREMES:

1. ESTABLISH THE MINIMUM AND MAXIMUM TEMPERATURE TO WHICH THE MATERIAL IS SUBJECTED.
2. CALCULATE THE EXPANSION & CONTRACTION RATE °C
3. CALCULATE THE EXPANSION & CONTRACTION AT INSTALLING TEMPERATURE. ACTUAL TEMPERATURE VS COEFFICIENT OF LINEAR THERMAL EXPANSION: SHEET LENGTH / WIDTH X 0.00015 X TEMPERATURE CHANGES = DIFFERENCE IN EXPANSION LENGTH.
 EXAMPLE A: SHEET LENGTH 2440 X 0.00015 X (54 °C - 27 °C) = 9.88 MM. PLEASE NOTE WHEN THE ACTUAL TEMPERATURE IS 27 °C THE TEMPERATURE OF THE SHEET IS 54 °C.
 EXAMPLE B: SHEET LENGTH 2440 X 0.00015 X (89 °C - 40 °C) = 17.64 MM. PLEASE NOTE WHEN THE ACTUAL TEMPERATURE IS 40 °C THE TEMPERATURE OF THE SHEET IS 89 °C.
4. CALCULATE 'CUT SHEET LENGTH' OR 'INSTALLATION WIDTH' AND 'GLAZING RABBET DEPTH' TO SUIT APPLICATION.
 NOTE: GLAZING RABBET DEPTH
 = GROOVE CUT OR FORMED TO RETAIN SHEET EDGE.
 = EDGE ENGAGEMENT WIDTH + TOTAL EXPANSION ALLOWANCE.

ENSURE A CONSULTING ENGINEER VERIFIES ALL GLAZING CALCULATIONS FOR THE PROJECT IN QUESTION.

Detail 2

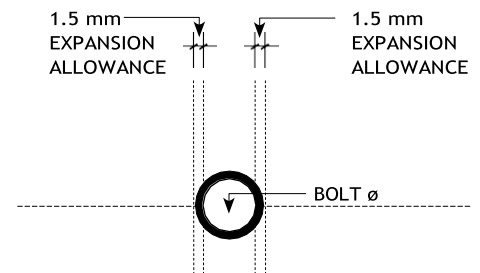

NOTE: PROVIDE OVERSIZE HOLES TO ALLOW FOR NATURAL EXPANSION & CONTRACTION.

SCREW FIXINGS MUST BE LOCATED IN CENTRE OF HOLE.

TYPICALLY USE HEX. OR DOME HEAD SCREWS OVER FULL FLAT WASHERS - TO ALLOW SHEET MOVEMENT BEHIND.

40 MM LENGTH WITH 15 MM APPROX. HEAD & 19 MM WASHERS FOR 10 MM THICKNESS.

DO NOT OVERTIGHTEN SCREWS.

Plaspanel®

Multi-purpose plastic panels

www.plaspanel.com.au



HDPE